

Automotive Acoustic Test Facilities

High-Performance Test Chambers, Enclosures
& Cabinets for Vehicle and Component Testing



- Hemi-Anechoic Chambers
- Pass-by Chambers
- Shake & Rattle Chambers
- Airbag Test Facilities
- Dynamometer Chambers
- Engine Test Chambers
- Mechanism Test Booths
- Reverberation Rooms
- End-of-Line Enclosures
- Acoustical Treatments
- Turnkey Solutions
- Over 50 Years Experience



Automotive Acoustic Test Facilities

**Controlled Acoustic Environment • Repeatable Test Accuracy
Proven Build Quality • Single Source Responsibility**

IAC Acoustics offers turnkey services for the design and manufacture of acoustical test chambers, sound enclosures and facility acoustical treatments for the automotive industry that will either isolate the test chamber from the ambient providing a specific, controlled interior acoustical environment in which to perform accurate and repeatable testing; or to enclose the test and contain and isolate high sound levels generated by the test from reaching the ambient. IAC will work with your team in designing a new test facility or overhauling and refurbishing an existing structure.

The design method and materials of construction will depend largely upon the performance criteria specified for any given project. All test parameters and ISO criteria will be carefully incorporated into solution design. Most projects will be shipped as modular components and assembled on site. IAC Acoustics will also provide factory pre-assembled chambers that are portable robust structures for smaller component testing and OEM applications.

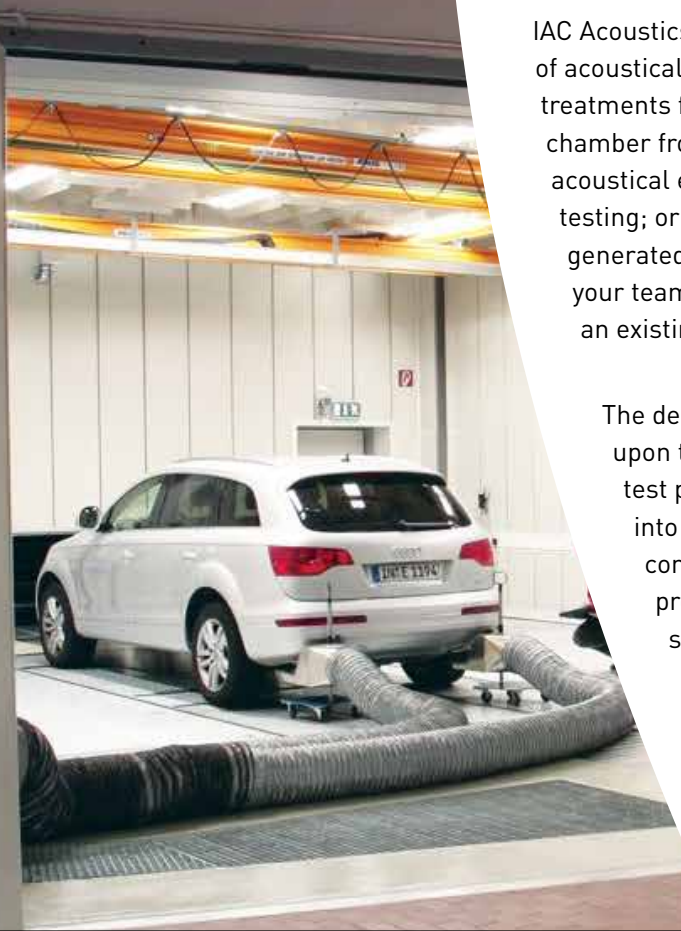

Acoustical Cabinet for AC Wheel Dyno

This high-performance, close fitting acoustic cabinet was custom designed for an OEM provider of testing and data acquisition systems for a major chassis and driveline R&D facility. The design incorporated easily removable sections for access and interchangeable axle interfaces to allow vehicle type flexibility.

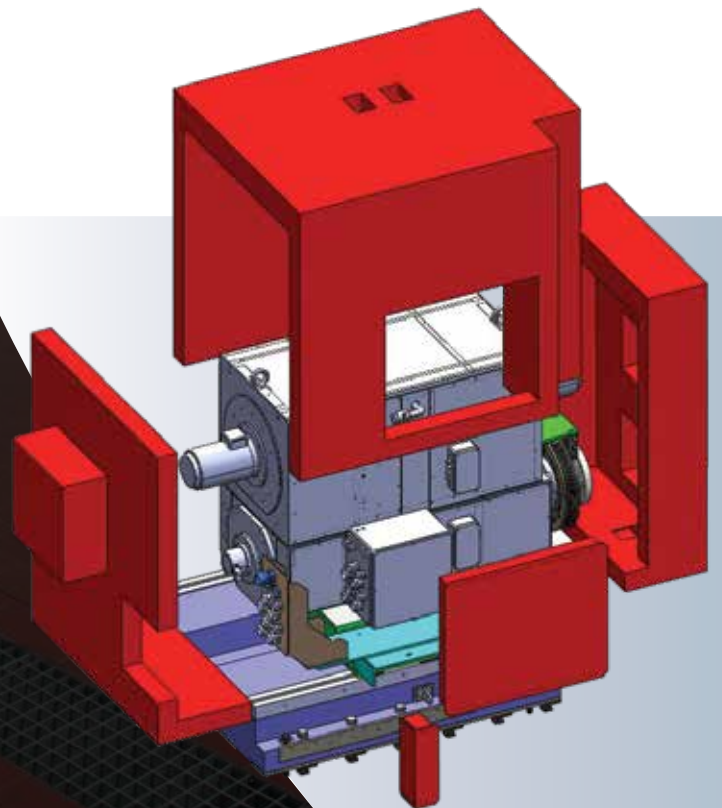

Uses for IAC Automotive Acoustic Test Facilities

IAC Acoustics test chambers and enclosures are typically designed and used for:

- Noise, Vibration and Harshness (NVH)
- Powertrain Engineering and Development
- Transmission and Brake Testing
- 4 Poster Testing
- Pass-by Noise Testing
- Seat Track Mechanism Testing
- Vehicle Climate Component Testing
- Material NRC and TL Research Testing
- Interior Cabin Noise Testing



Automotive AC Unit
Test Chamber



Bag Burst Test Enclosure



Wheel Dyno
Acoustic Cabinets



Car Dyno Cell



Reverb & Anechoic
Test Suite



Truck Dyno Cell

Making the World a Quieter Place

Markets Served by IAC Acoustics



Architectural

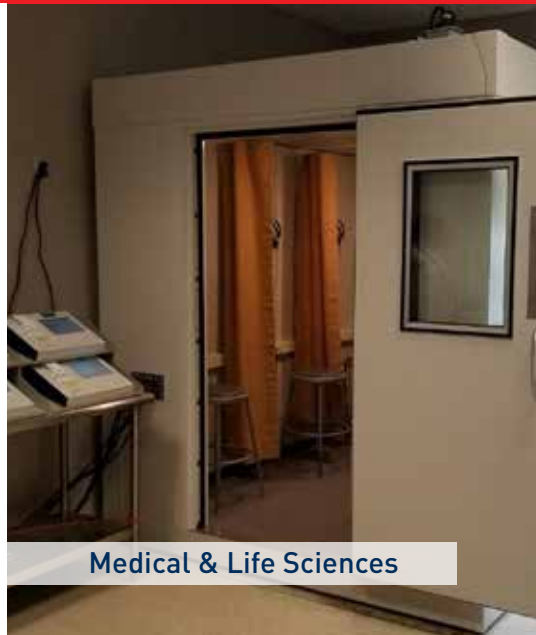

Medical & Life Sciences

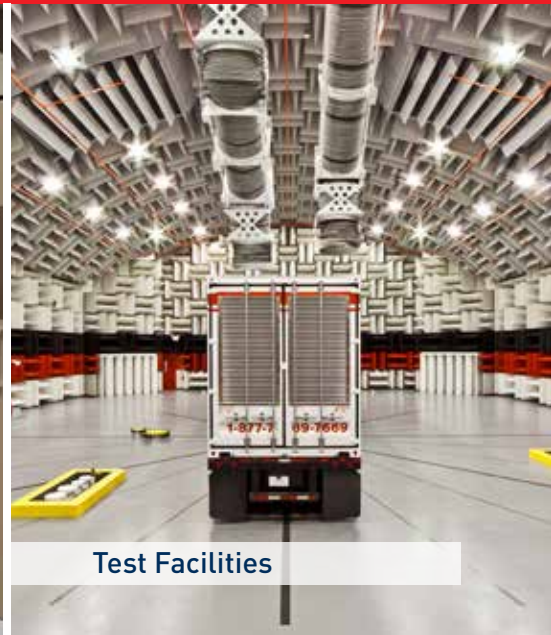

Test Facilities



Industrial



Dyno Test Rooms



HVAC

www.iacacoustics.com

Follow Us

