

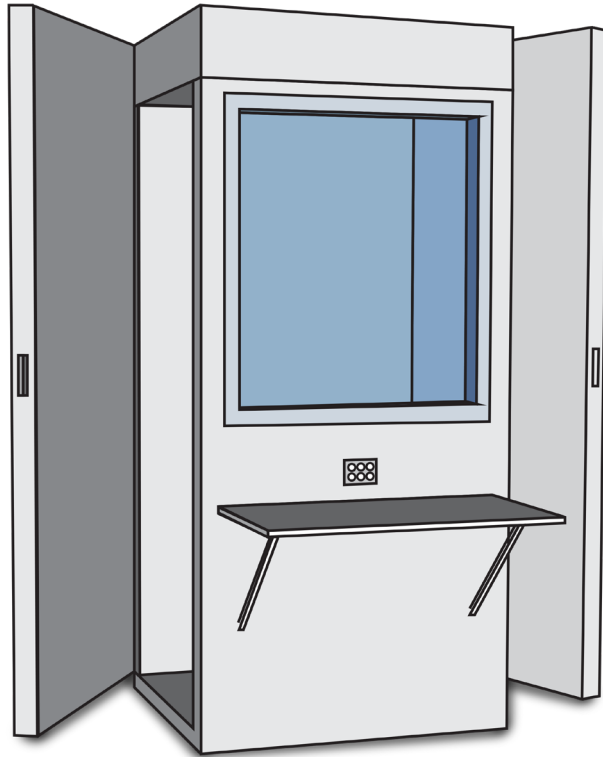

Data Sheet

254 Series Mini-Max Sound Shelter



The **254 Series Mini-Max Sound Shelter** design is engineered to allow flexibility in any environment. The 254 Series can be quickly transformed to achieve a right or left hand configuration, without any disassembly of components, by any staff member without any tools.

Ideally suited for:

- Industrial — Monitoring Audiometry
- Public School — Identification Audiometry
- Speech Audiometry (through earphones)
- Psychological Data Recording
- Hearing Health Professionals
- Mobile Test Vans

Equipped with:

- Noise-Lock® magnetic-seal doors for safety
- Tranquil-Air® silent forced ventilation system
- Outside mounted shelf (16" x 32")
- Casters for ready positioning or repositioning of booth

Typical Plan

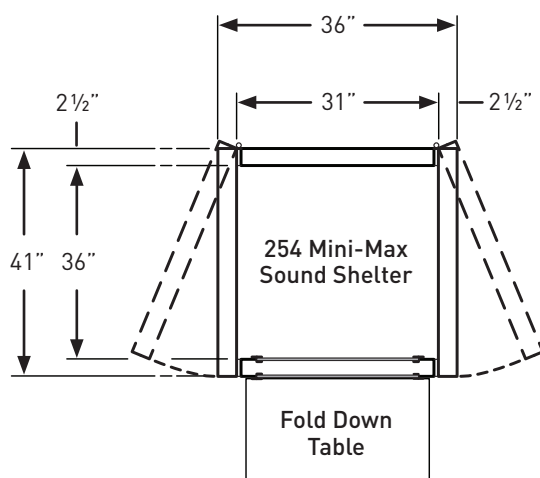

Ready to go to work:

- Shipped fully equipped and assembled — passes through any normal 32" (813 mm) wide door
- Inside Dimension: 31" wide x 36" deep x 66" high (788 mm x 914 mm x 1676 mm)
- Outside Dimension: 36" wide x 41" deep x 75.5" high (914 mm x 1041 mm x 1905 mm)
- Floor area is less than 8 sq. ft. (0.74 sq m)
- Net weight: 825 lbs. (375 kg)
- Shipping weight: 890 lbs. (405 kg)





Data Sheet

254 Series Mini-Max Sound Shelter



Net Weight:

890 lbs.

Panel Construction:

2 1/2" thick Noishield® panels

Largest Panel Size:

3'-5" wide x 5'-6" long x 2 1/2" thick
Customer to ensure adequate site access

Interior Surfaces:

22ga. galvanized perforated steel

Exterior Surfaces:

14ga. cold rolled solid steel

Floor Interior Surface:

11ga. hot rolled steel

Finish:

Textured powder coated

Door:

(2) 3'-5" wide x 5'-6" high (clear opening) doors supported on (2) architectural heavy duty butt hinges integrally mounted within the door leaf and panel frame

Note:

- Self-aligning magnetic compression seals are mounted on the top and sides of the door leaf
- A self-adjusting drag seal is supplied for the bottom of the door

Window:

(1) 2' wide x 2'-6" high aluminum frame with double glazed 1/4" thick laminated safety glass

Shelf:

(1) 1'-4" wide x 2'-8" deep externally mounted shelf for audiometer

Electrical:

- Switch mounted on lighting fixture inside the room operates the fan and light
- (1) 10' long drop cord provided for connection to power

Note:

- Booth is factory UL certified and labeled

Audiometric Jack Panel:

Completely pre-wired, flush-mounted jack panel consisting of (6) switchcraft 3-wire phone type jacks

Booth Options:

Ventilation:

Ceiling panel contains an all-in-one forced ventilation system and intake and exhaust silencers

Color:

"Khaki" standard or choice of (9) standard colors

Floor Covering:

Industrial nylon carpet, to match paint color selection with 3/8" thick underlayment and 2-1/2" H black cove base molding included

Noise Reduction:

Octave Band Center Frequency, (Hz)	125	250	500	1K	2K	4K	8K
Noise Reduction, dB	18	32	38	44	51	52	50

Note:

Noise reduction is defined as the measured difference between the sound pressure levels outside and inside the booth

Optional Equipment:

- Vibration isolators are available where structure-borne noise is a problem
- Intercom systems

Site Requirements:

- Customer to provide a finished floor which is within +/- 1/4" of level in 10 non-cumulative feet
- 4" minimum clearance is required between the exterior of testing booth and host facility walls/ceiling

